

Type 1940

Thread mill with GCT MicroSpeed diamond coating

Applications / Advantages:

- Ideally suited for inner thread in IMS, aluminium and copper
- High dimensional accuracy and process capability due to application-specific design



MicroSpeed diamond coating - Made by GCT in Germany

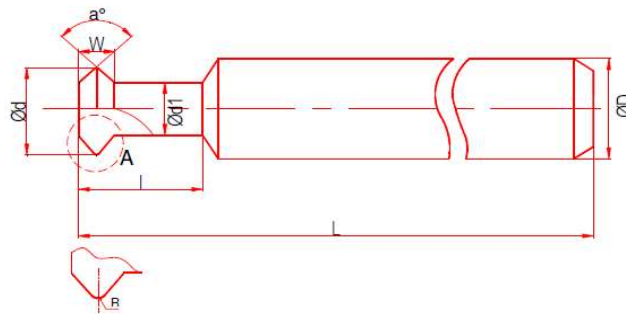

Metric Thread	l
M1.6 x 0.35	4.0
M2 x 0.4	4.0
M2.5 x 0.45	5.0
M3 x 0.5	6.0
M4 x 0.7	6.0
M5 x 0.8	6.0

* Additional sizes and flute lengths made to order.

Standard Version:

- tolerances according to GCT specifications
- made of solid carbide

Manufactured by:

GCT, GmbH
Josef-Bayer-Srt.3
D-88250 Weingarten
Germany
Rev- 04/2020

Tel.: +49-(0) 751- 50 91 58 0
Fax: +49-(0) 751-50 91 58 99
E-Mail: info@gctool.com
www.gctool.com
Subject to technical changes



Distributed by:

Carbide Related Technologies, Inc.

355 Sackett Point Road, #5

North Haven, CT 06473

T-203-281-1266 F-203-248-9331

www.carbiderelatedtech.com