



PCB LINE

HI-TECH VACUUM



© iVision Vacuum

EN

 **iVISION**[®]
ITALIAN VACUUM

INDUSTRIAL VACUUMS FOR PRINTED CIRCUITS

The high level of technology and the constant growth of experience that has always characterized the company iVISION, have led us to develop a new range of industrial vacuum cleaners with side channel turbines, dedicated to machines that produce printed circuit boards such as drilling machines, milling or contouring, that need an accurate and efficient suction of chips/powder to achieve maximum accuracy during the work process and a perfect end product.

The line dedicated to this sector is particularly versatile and complete; it includes vacuum cleaners for single-spindle and multi-spindle machines, with centralized vacuum systems for managing an entire production facility, thus offering its customers a wide choice in order to suit every need.



THE MOST ADVANCED TECHNOLOGY IN THE MARKET

Numerous tests, hi-tech patents, and careful monitoring of details allows iVision Srl to be among the reference global suppliers in this product sector. The excellence of the design and construction techniques create a highly flexible material handling system, able to adapt to customer needs.

The vacuums are on wheels with centralized systems easy to use and virtually maintenance-free with innovative technical solutions, this is used to protect the units over time.

Optional accessories, such as the touch screen system, were developed specifically for the printed circuit industry.

The principal advantages of the PCB line are:

- Ability to modulate the frequency of the motor and thus optimize the consumption of electricity according to the real requirements of the machine.
- Suction pump with high efficiency side channel turbine specifically developed for this type of machine, which are equipped with safety valves.
- Touch screen – able to clearly and easily indicate the level of dirt of the filter; this data can be sent directly to the machine tool control panel and thus start the automatic filter cleaning procedures
- Optional cleaning kit that can be utilized by the operator for cleaning the machine after work.
- Increase in the production of the operator thanks to the minimal level of maintenance.

We would like to thank Schmolli Maschinen GmbH and Picesse Elettronica s.r.l. for authorizing us to use the image of the machinery.

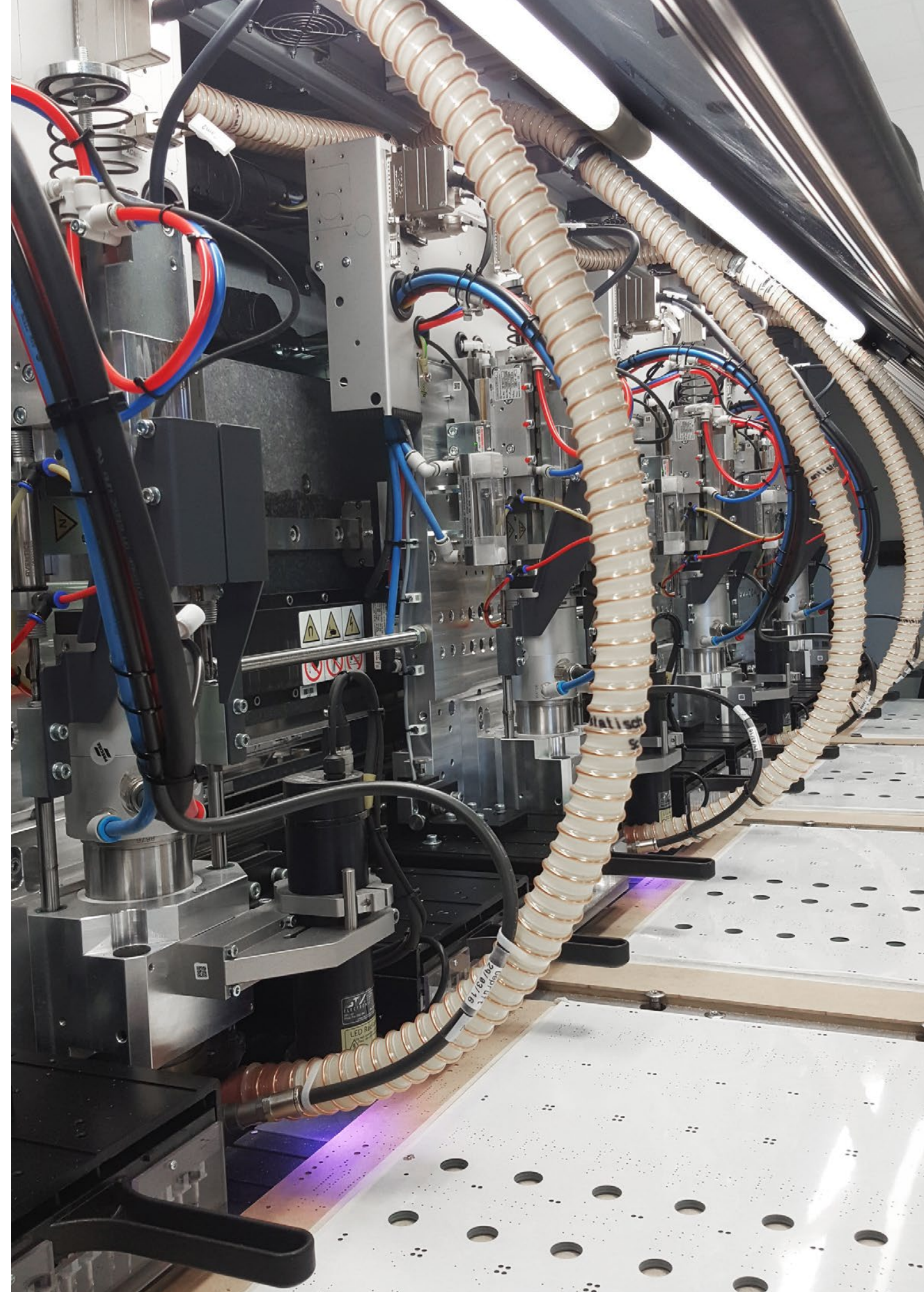

VACUUMS BY MEASURE



In order to meet your needs, all of our vacuums are on wheels (also our centralized systems), and our containers for the collecting of chips can be of various capacities. Starting from the smallest models, that are compact and manageable for one quick emptying process and easily moveable, up to the big collection containers of 1,000 liters for heavy duty work.

For large businesses requiring 24-hour production, iVISION produced a centralized system with a continuous unloading cycle mediated by a rotary valve.

iV1

MADE IN ITALY QUALITY

The vacuums of the iV1 model of the PCB line are the most compact of the iVision range, and are used for the collection of chips/dust in small machines using one or two spindles. The compact dimensions allow the positioning of the machine even in very limited spaces.

The excellent performance of the side-channel turbines allows one to take full advantage of their efficiency. The study and the design research, the sturdy materials and the simple design, are characteristics of a product entirely made in Italy; a real guarantee on the industrial market.

CUSTOMIZED PRODUCTS

Every model has been created, produced and assembled to meet every specific request, producing, above all, the creation of a product capable of working side by side of the machine tool of every client.

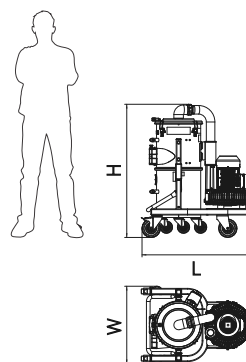

STANDARD SUPPLY

- Side-channel turbine
- Safety valve
- Structure completely made of steel
- Anti-scoff wheels with parking brake
- Container capacity: 38 Lt
- Quick release of the container
- Silencer with respect to the regulations in force
- M Class filter with PTFE membrane

OPTIONAL

- Remote control
- PVC bags kit for the collection of chips
- Automatic or semi-automatic filter cleaning system
- Loading cell with a "full container" alert system
- HEPA Filter
- Antistatic kit



PCB

		iV1 - 2.2 - 38 - 310	iV1 - 3 - 38 - 310
FREQUENCY	HZ	50	50
POWER	KW	2,2	3
VOLTAGE *	V	400	400
WATER LIFT MAX	mbar	300	310
AIR FLOW MAX	m3/h	310	310
INLET	N°	1	1
SUCTION INLET	Ø mm	100	100
VOLUME	Lt	38	38
DIMENSIONS	H	104	104
	L	90	90
	W	63	63
WEIGHT	kg	90	95

* Voltage variable at the request

All data and all images are subject to variations. Reproduction of images and texts, even partial, is prohibited.

iV2

MADE IN ITALY QUALITY

The vacuums of the iV2 model of the PCB line are the most sold of the wheeled vacuums of the iVision range, and are utilized for the collection of chips/dust of machines with 2 to 6 spindles for drilling / milling. The compact size allows the placement of the vacuum even in environments with limited space.

The excellent performance of the side-channel turbines allows one to take full advantage of their efficiency. The study and the design research, the sturdy materials and the simple design, are characteristics of a product entirely made in Italy; a real guarantee on the industrial market.

CUSTOMIZED PRODUCTS

Every model has been created, produced and assembled to meet every specific request, producing, above all, the creation of a product capable of working side by side of the machine tool of every client.

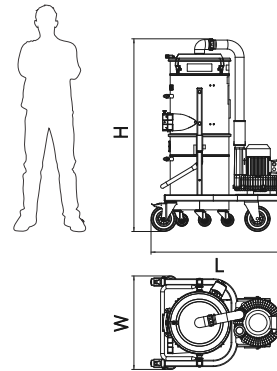

STANDARD SUPPLY

- Side-channel turbine
- Safety valve
- Visual filling indicator
- Structure completely made of steel
- Anti-scoff wheels with parking brake
- Container capacity: 100 Lt
- Quick release of the container
- Silencer with respect to the regulations in force
- M Class filter with PTFE membrane

OPTIONAL

- Remote control
- Touch screen
- PVC bags kit for the collection of chips
- Automatic or semi-automatic filter cleaning system
- Loading cell with a "full container" alert system
- HEPA Filter
- Antistatic kit
- Cyclonic pre-filter to extend filter life



picture for illustrative purpose only

PCB		iV2 - 2.2 - 100 - 310	iV2 - 3 - 100 - 310	iV2 - 4 - 100 - 310
FREQUENCY	HZ	50	50	50
POWER	KW	2.2	3	4
VOLTAGE *	V	400	400	400
WATER LIFT MAX	mbar	300	310	320
AIR FLOW MAX	m3/h	310	310	310
INLET	N°	1	1	1
SUCTION INLET	Ø mm	100	100	100
VOLUME	Lt	100	100	100
DIMENSIONS	H	152	152	152
	L	104	104	104
	W	73	73	73
WEIGHT	kg	115	115	115

* Voltage variable at the request

All data and all images are subject to variations. Reproduction of images and texts, even partial, is prohibited.

iv3

MADE IN ITALY QUALITY

The vacuums of the iv3 model of the PCB line are the most powerful of the wheeled vacuums and are utilized for the collection of chips/dust in large drilling machines.

In their customized version, the vacuums of the iv3 line can be used with an inverter and can be transformed into centralized vacuum systems.

The excellent performance of the side-channel turbines allows one to take full advantage of their efficiency. The study and the design research, the sturdy materials and the simple design, are characteristics of a product entirely made in Italy; a real guarantee on the industrial market.

CUSTOMIZED PRODUCTS

Every model has been created, produced and assembled to meet every specific request, producing, above all, the creation of a product capable of working side by side of the machine tool of every client.

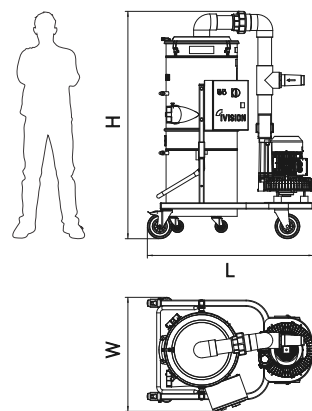

STANDARD SUPPLY

- Side-channel turbine
- Safety valve
- Structure completely made of steel
- Anti-scoff wheels with parking brake
- Container capacity: 160 Lt
- Quick release of the container
- Silencer with respect to the regulations in force
- M Class filter with PTFE membrane

OPTIONAL

- Remote control
- PVC bags kit for the collection of chips
- Automatic or semi-automatic filter cleaning system
- Loading cell with a "full container" alert system
- HEPA Filter
- Antistatic kit
- Cyclonic pre-filter to extend filter life
- Frequency inverter
- Rotary valve for nonstop unloading (24/7)



PCB		iv3 - 5.5 - 160 - 550	iv3 - 7.5 - 160 - 550	iv3 12,5 160 1100
FREQUENCY	HZ	50	50	50
POWER	KW	5,5	7,5	12,5
VOLTAGE *	V	400	400	400
WATER LIFT MAX	mbar	300	320	300
AIR FLOW MAX	m3/h	550	550	1100
INLET	N°	2	2	2
SUCTION INLET	Ø mm	100	100	100
VOLUME	Lt	160	160	160
DIMENSIONS	cm	H	180	180
		L	126	126
		W	84	84
WEIGHT	kg	190	200	280

* Voltage variable at the request

All data and all images are subject to variations. Reproduction of images and texts, even partial, is prohibited.

iV CUSTOM HI-TECH VACUUM

CENTRAL SYSTEM

Advantages of our intelligent system:

- Cyclonic pre-filter to intercept and block the majority of the suctioned dust before reaching the filter
- Possibility of electronically modulating the installation and optimization of the energy consumption based on the real need of the client (drastic reduction in electric consumption)
- Touch screen enables the signaling in a clear and unmistakable way the level of filter contamination; this data can be sent to the control panel of the machine tool to start the automatic filter cleaning
- Visual and acoustic alarm that the container has reached maximum filling capacity. Thus, making a manual intervention for the daily cleaning of the filter unnecessary, given that this comes carried out automatically
- Eliminating of every type of negligence on part of the operator
- Possibility of positioning the control panel inside the factory or to communicate the centralized management of the data through a Wi-Fi device to the person in charge of machine maintenance
- Flexibility of mounting the centralized system according to the available space of the client (installation can be done horizontally, vertically, L-shaped, etc.)

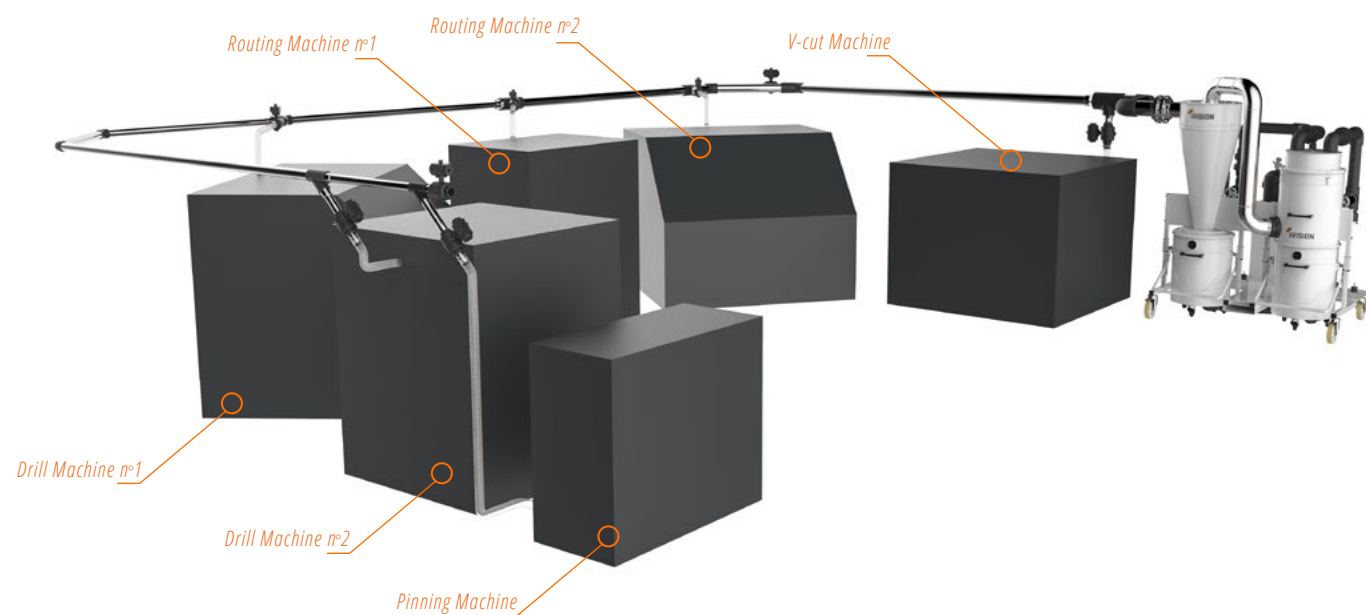

picture for illustrative purpose only



		12.5+12.5 - 2600
POWER	kW	12,5x2
AIR FLOW MAX	m³/h	2600
VOLUME	Lt	160x2
FILTERING SURFACE	m²	10

TOUCH SCREEN HI-TECH VACUUM

HUMAN MACHINE INTERFACE

The vacuum cleaner is equipped with a touch screen unit on the front. It allows the operator to quickly and easily monitor the level of contamination of the filter.

Thanks to such a device, the operator is able to recognize in real time the filter condition and the efficiency of the whole vacuum cleaner. Afterwards, the operator can choose to clean the filter (in manual or automatic mode) and also manage the remote Start&Stop control option.

Once the filter is completely clogged, the unit will automatically warn the operator of the need to replace the filter utilizing:

- An audible signal.
- A visual signal.

On the round screen you can find the following icons:

Scale-LED: it shows the level of contamination that the filter has reached. The measurement is made in a scientific and non-empirical manner through a sophisticated system of sensors controlled by a PLC exclusively for this purpose.

- 1 **Manual ON/OFF:** if you select this icon - it allows you to simply start the vacuum system with the simple touch of your finger.
- 2 **Automatic ON/OFF:** if you select this icon - the motor is switched on / off directly from the machine.
- 3 **Automatic Filter Cleaning:** if you select this icon - an electric contact enables the cleaning of the filter in a completely automatic and programmed manner.
- 4 **Semiautomatic Filter Cleaning:** if you select this icon - it is used to clean the filter immediately.



All data and all images are subject to variations. Reproduction of images and texts, even partial, is prohibited.



CYCLONIC PREFILTER

HI-TECH VACUUM

Strongly recommended whenever possible, the pre-filter is positioned between the vacuum and the chip generating machine, as the first point of collection of the collected material. It is specially used to preserve the life of the filter inside the vacuum unit. It retains most of the collected material and can have a cone or cylindrical shape and serves as a mechanical filter. Through a tangential entry the collected material is centrifuged into its interior until its speed gradually decreases and the material falls to the bottom of the collecting unit due to the force of gravity. Such a process ensures that only a relatively low percentage of collected dust or chips manages to actually reach the real filter positioned in the upper part of the vacuum cleaner.

The cyclonic pre-filter becomes almost mandatory for fine or very fine powders, which are very likely to clog the filter quickly, compromising the smooth operation of the entire system, but are only recommended for large, heavy chips.

The main advantage of the cyclonic pre-filter is to protect the filter of the vacuum cleaner from quickly clogging, thus extending its life before replacement and significantly reducing the maintenance of the entire system.



160 Lt



1.000 Lt

FREQUENCY INVERTER

HI-TECH VACUUM

Compact technology, powerful and built-to-last this characterizes the frequency inverter that regulates and manages the performance of iVision vacuums. The inverter operates the normal work of the turbines or intervenes instantaneously in all of the possible emergencies that may occur by increasing or decreasing the RPM of the engines in order to ensure the same performance for the system even in the case that a machine that the vacuum is attached to stops working.

For example, in the case that a turbine breaks or the filter clogs, the suction power is reduced and in that moment the sensors enable the inverter to increase the engine speed in order to compensate for the loss in power. All this prevents the need for production to stop or potential damage to the machines especially in cases where the vacuums are attached to more than one machine in a factory.

In addition to ensuring the highest performance of the factory, it's able to optimize the consumption of power by monitoring the number of machines working. For example, in the case of a factory with machine tools with only some working and others that are not, the inverter can adjust the consumption of electricity of the entire system to the minimum amount necessary.

It features an incomparable reliability and ease of use that can be programmed to perform even the most complex operations. Additionally, it is designed so that air ventilation is not in contact with the electronics.



Turbine n°1



Turbine n°2



Turbine n°3

All data and all images are subject to variations. Reproduction of images and texts, even partial, is prohibited.

REMOTE START & STOP

HI-TECH VACUUM

The kit allows the automatic switching on and off of the vacuum cleaner simultaneously with the machine tool when they are connected. This can occur in three different ways:

- The vacuum gets switched on by contact without electricity "potential free contact".
- The vacuum gets switched on with a 24V contact.
- The vacuum gets switched on with a 230V contact.

The advantages are:

- Energy-saving, as the vacuum cleaner is switched on only when the machine is working.
- Noise level reduction, because the vacuum cleaner is on (and makes noise) only when the machine is working.
- Optimization of operators' time as one no longer needs to personally attend to the machine in order to switch it on or off.



All data and all images are subject to variations. Reproduction of images and texts, even partial, is prohibited.

CLEANING KIT

Ø 50 mm

HI-TECH VACUUM

The cleaning kit is usable on all of the series and consists of a robust, anti-abrasion tube that ends at the extremities with special zinc-plated steel accessories capable of transporting, without any obstacle, chippings and oil from the machine tool to the vacuum collection tank.

The vacuum suction tube is easily stored on the unit on an external support that facilitates the movement of the vacuum in a way that eliminates any hassle the tube can create for the operator. Additionally, it allows the avoidance of oil leakage during the maneuvers of the vacuum.



THE IVISION HEALTH SAFETY SOLUTION

CREATED FOR YOU

48000 Lt in 8 hour work-day means about 100 Lt / min: this is the quantity of air a worker breathes. The two main ways harmful substances produced during the working of materials are absorbed

into the body are through the lungs and skin. Less oxygen means more physical exertion and an elevated risk of mishaps and illnesses specific to this type of working environment.



QUALITY & HEALTH

Organizations that see the constant and dizzying employment of new chemical products that take-over the organs in control of olfactory sensing and manifest problems of later illness,

have the power to entrust in a machine that responds perfectly to the demands of the proper collecting of materials after their processing, that also aids in the protection of the life.

WHY CHOOSE IVISION?

The high degree of technologic innovation of our vacuums, the continuous attention to the health of the workers, the planning of specifically optimized series for every category of material and every type of work, the possibility of creating ventilation systems that transfer polluted air outside of the working environment, are what make the iVision series the best partner for your work, for today and for always.



THE ITALIAN VACUUM SOLUTION

iVision is a reference point in the sector of industrial vacuum cleaners and heavy duty industrial vacuums. In the course of a few years, iVision has managed to grow quickly and gain significant market shares all over the world.



headquarters located in Cattolica (Rimini) Italy

iVision headquarters are located in Cattolica (Rimini) in Italy. All our products are 100% Made In Italy. Our innovative industrial vacuum cleaners have been used by facilities and plant maintenance personnel worldwide.

The sales network of iVision srl is covering the whole world with agents and distributors and the share of exports of iVision vacuum cleaners in Europe, America, Asia and even Australia has been growing constantly.

iVision is naturally oriented to the export which takes at the moment about 80% of the total production.



OUR SECRET

Hard work, professionalism, passion, research and, last but not least: huge investments and the unique capability for analysing combined with an innovative spirit in the market segment of industrial vacuum cleaners. iVision is a customer-oriented company. Our Sales team together with the Technical and R&D department works constantly to understand and also anticipate the customers' requirements and wishes.

WHY IVISION

iVision is considered by all its partners a company founded on strong values, such as respect for environment and people. We create long-term partnerships with agents, dealers, official distributors and also worldwide known OEMs, who understand the importance of establishing a win-win relationship with a competent and fair partner like iVision.

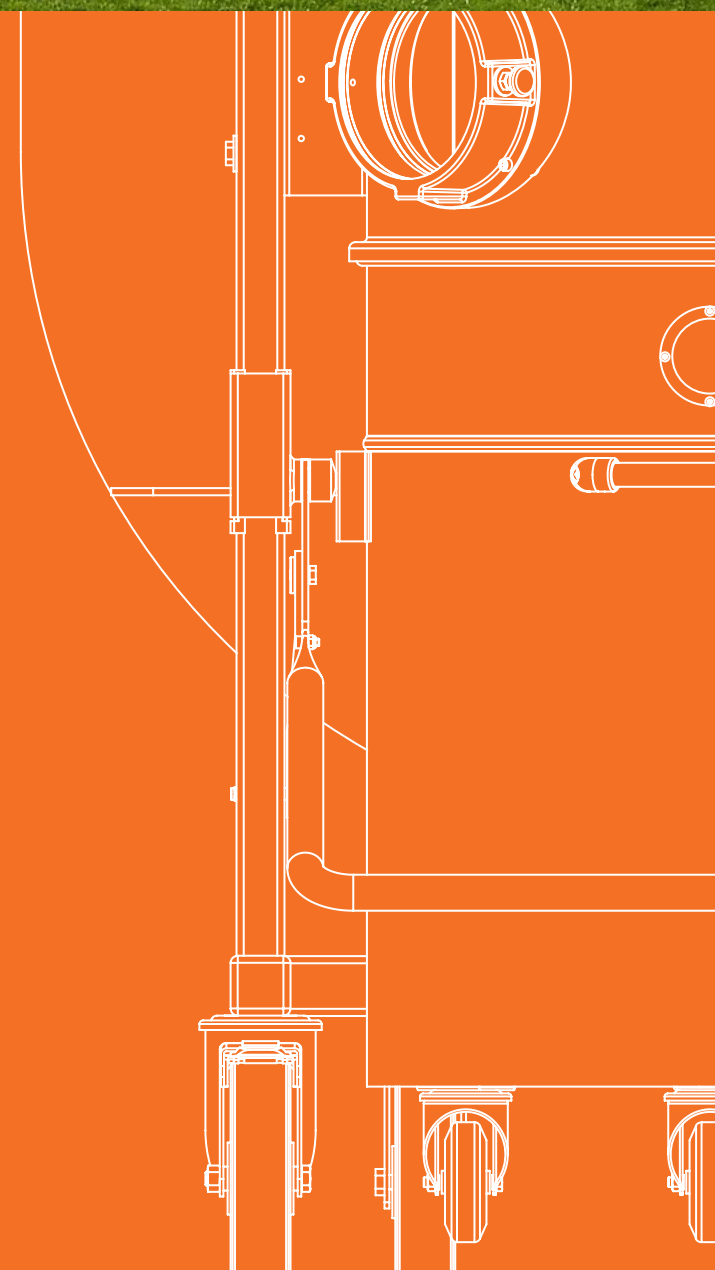



THE ITALIAN VACUUM SOLUTION

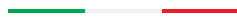

iVision srl

Via Mercadante 14
47841 Cattolica (RN)
Italy

iVision Industrial Vacuum LLC

4235 NE 6th Avenue,
Oakland Park
Ft. Lauderdale, FL 33334
USA

Phone

+39 0541 833094

Fax

+39 0541 205707

Email

info@ivisionvacuum.com

Website

www.ivisionvacuum.com

